

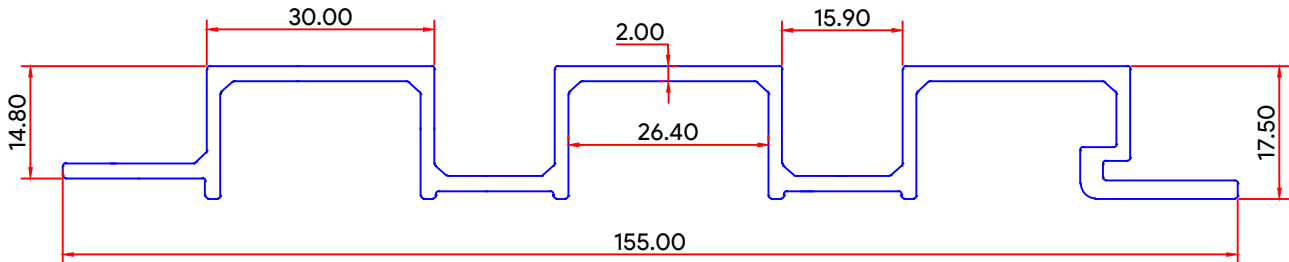

GATE & RAILING SECTION

ARCHITECTURAL

SEC. NO. : 6010



WEIGHT. : 5.140 KG / 12'

SEC. NO. : 8354-R

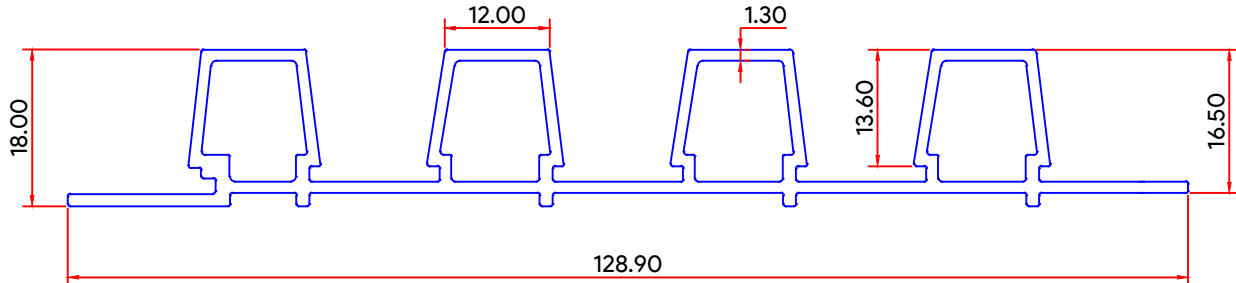

WEIGHT. : 4.080 KG / 12'

SEC. NO. : 8354

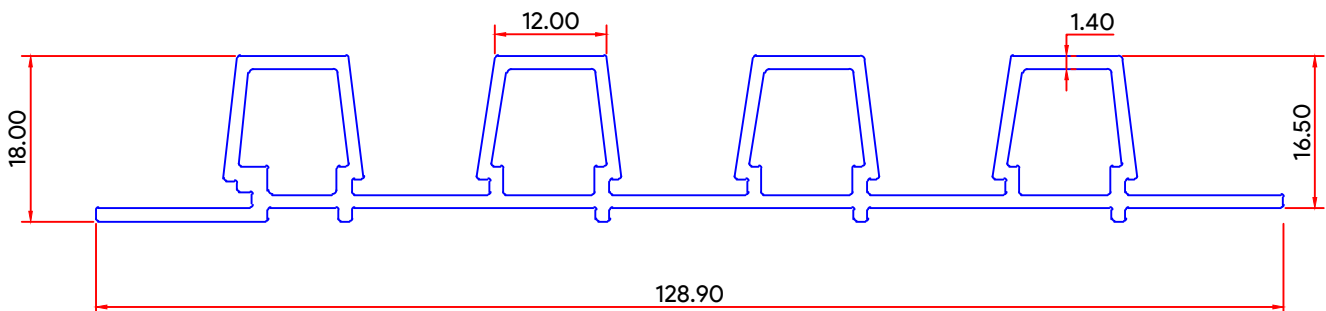

WEIGHT. : 5.180 KG / 12'



GATE & RAILING SECTION

ARCHITECTURAL

SEC. NO. : 6035

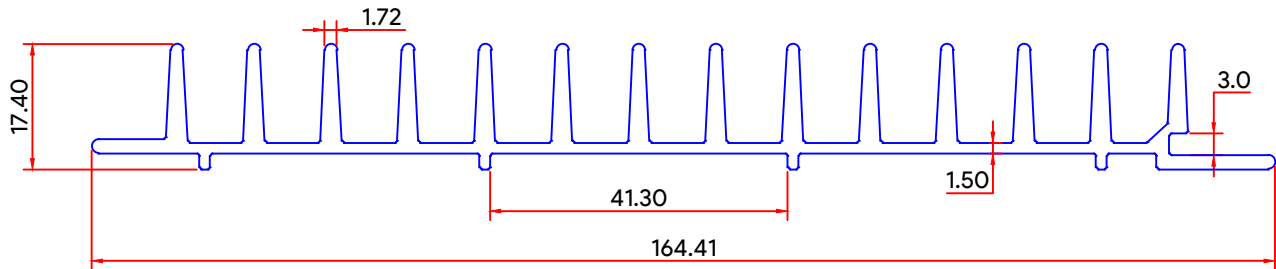

WEIGHT. : 7.083 KG / 12'

SEC. NO. : 8471-R

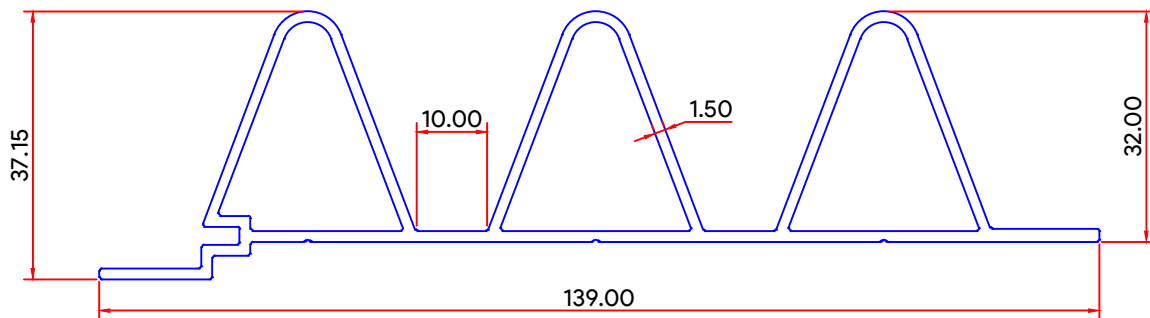

WEIGHT. : 5.270 KG / 12'

SEC. NO. : 8467

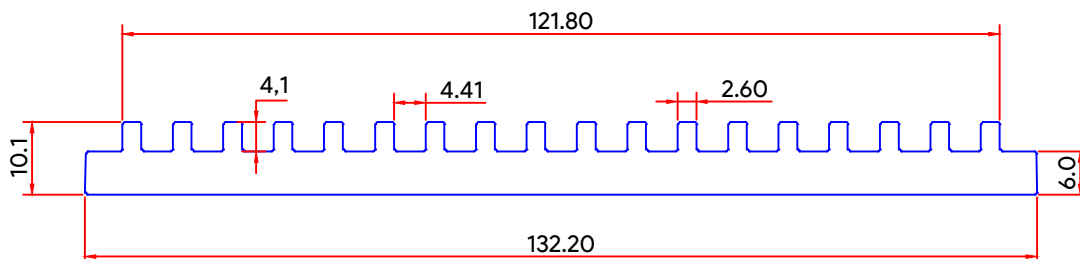

WEIGHT. : 9.720 KG / 12'



GATE & RAILING SECTION

ARCHITECTURAL

SEC. NO. : 6045

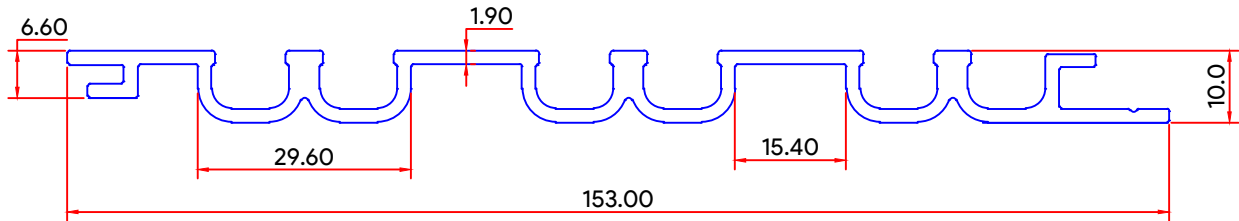

WEIGHT. : 4.815 KG / 12'

SEC. NO. : 8441

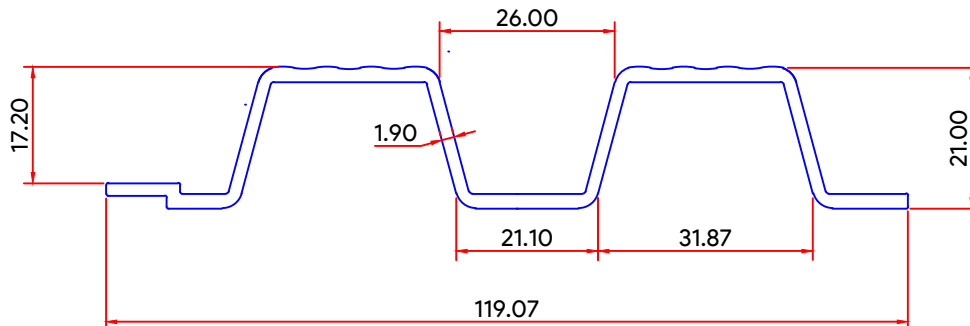

WEIGHT. : 3.470 KG / 12'

SEC. NO. : 8442

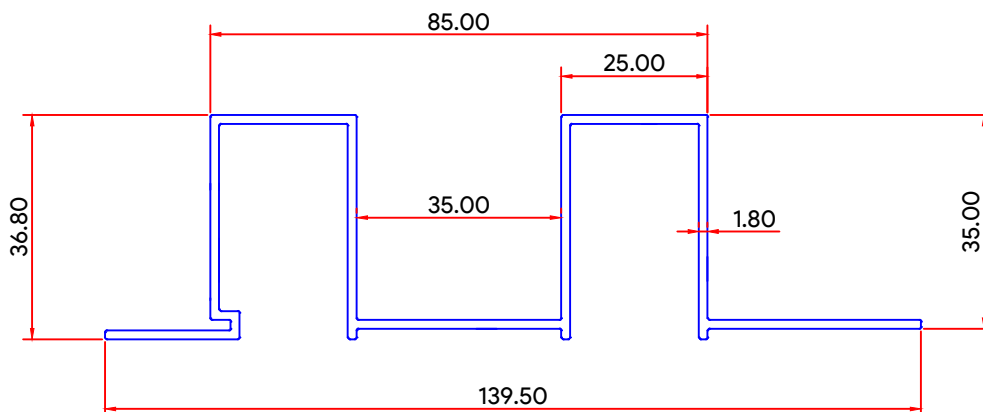

WEIGHT. : 4.250 KG / 12'



GATE & RAILING SECTION

ARCHITECTURAL

SEC. NO. : 8469

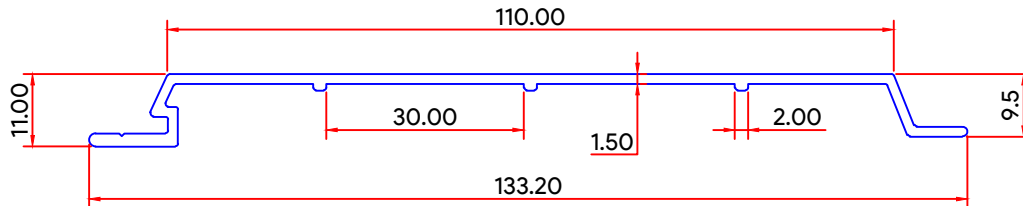

WEIGHT. : 2.350 KG / 12'

SEC. NO. : 8388

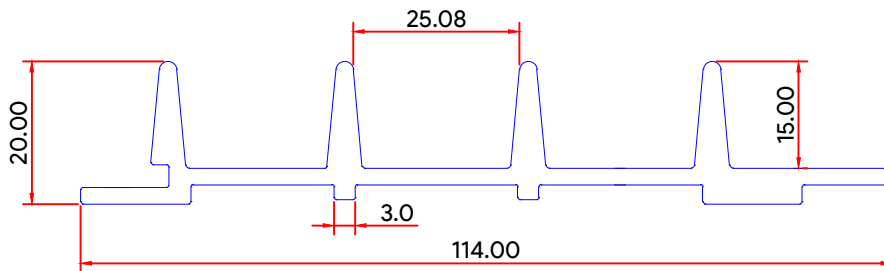

WEIGHT. : 5.250 KG / 12'

SEC. NO. : 8387

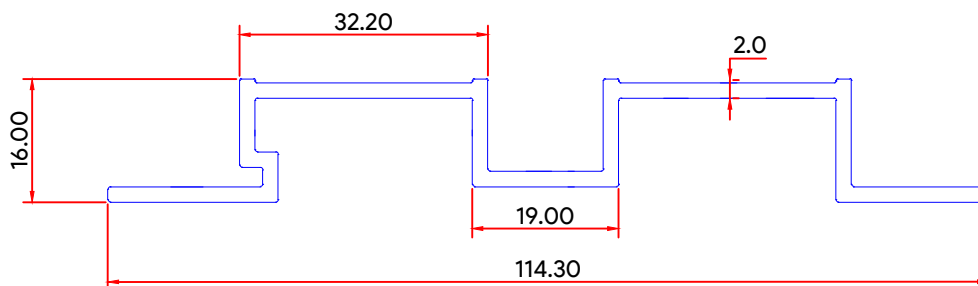

WEIGHT. : 3.400 KG / 12'



GATE & RAILING SECTION

ARCHITECTURAL

SEC. NO. : 8432

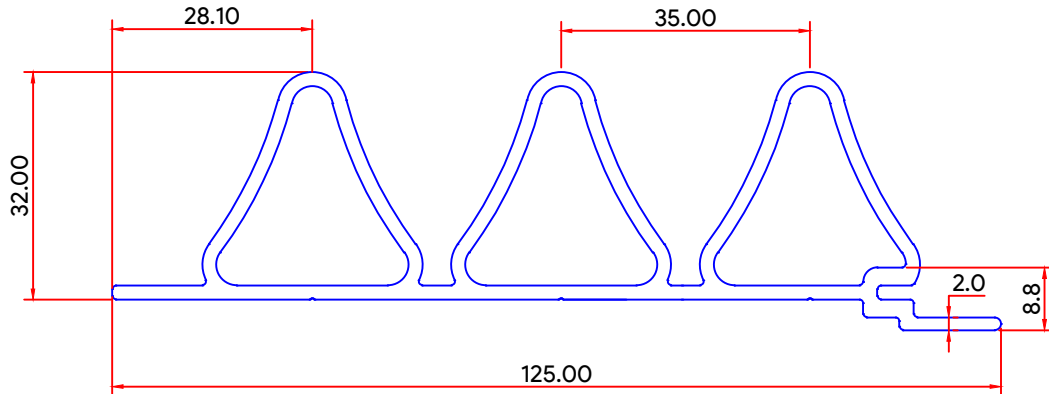

WEIGHT. : 6.700 KG / 12'

SEC. NO. : 6053

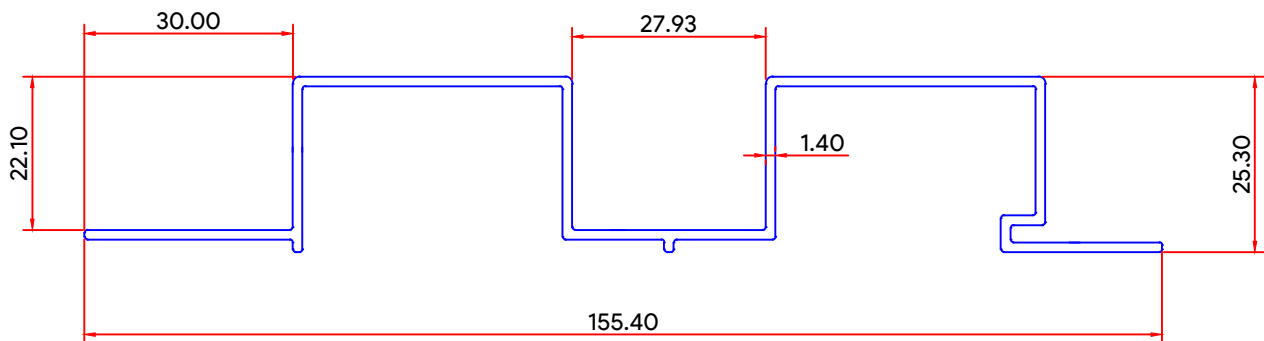

WEIGHT. : 3.570 KG / 12'

SEC. NO. : 6010-R

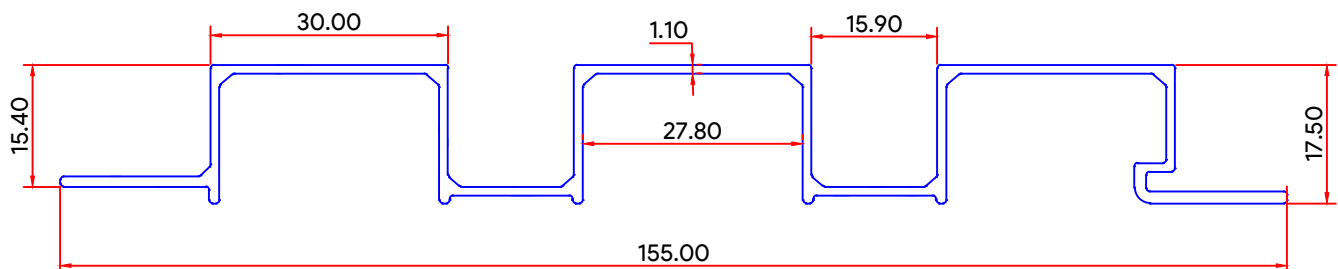

WEIGHT. : 3.060 KG / 12'



GATE & RAILING SECTION

ARCHITECTURAL

SEC. NO. : 6105

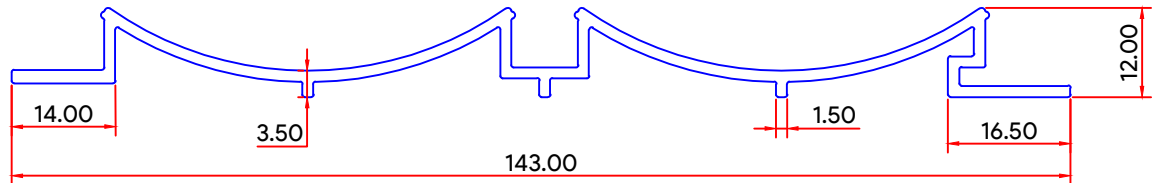

WEIGHT. : 2.970 KG / 12'

SEC. NO. : 6101

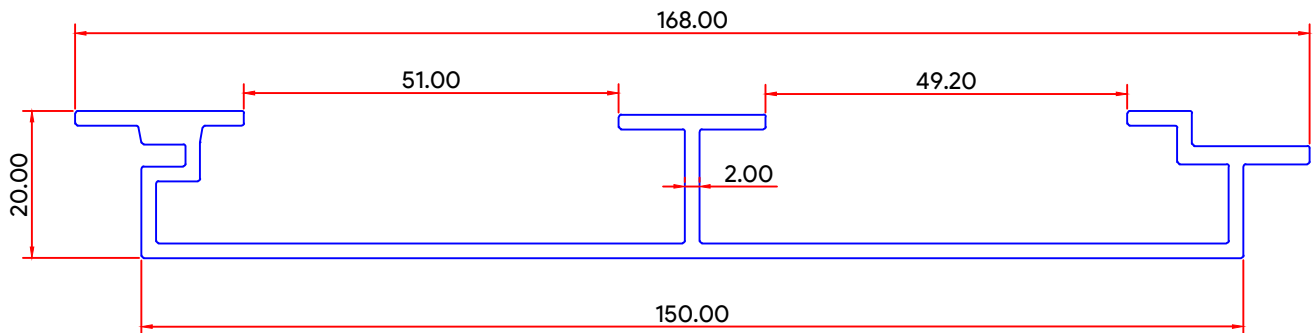

WEIGHT. : 5.600 KG / 12'

SEC. NO. : 6147

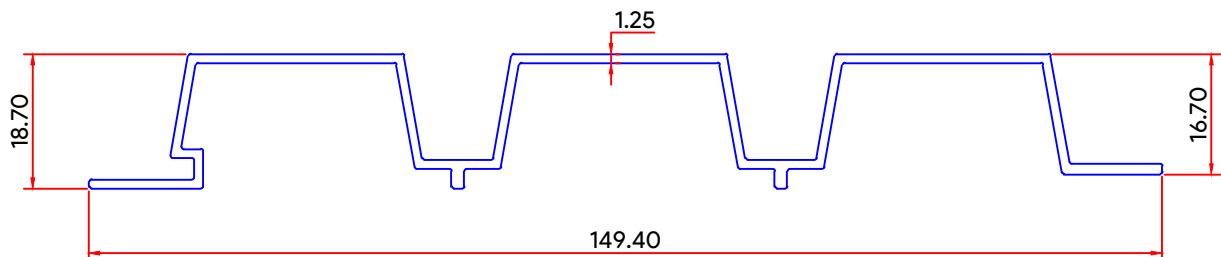

WEIGHT. : 3.000 KG / 12'



GATE & RAILING SECTION

ARCHITECTURAL

SEC. NO. : 6148

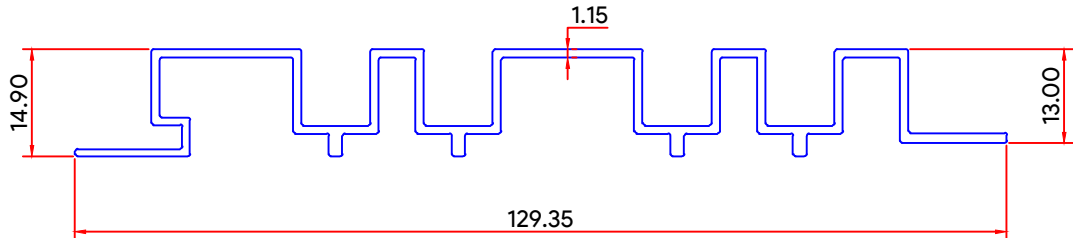

WEIGHT. : 3.045 KG / 12'

SEC. NO. : 8157

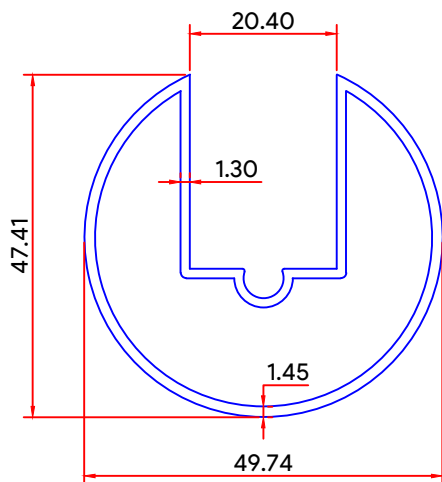

WEIGHT. : 2.820-3.000 KG / 12'

SEC. NO. : 7117

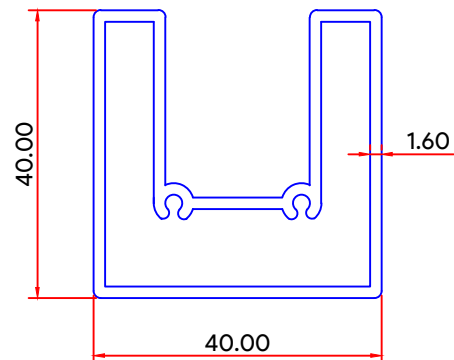

WEIGHT. : 3.300-3.500 KG / 12'

SEC. NO. : 6156

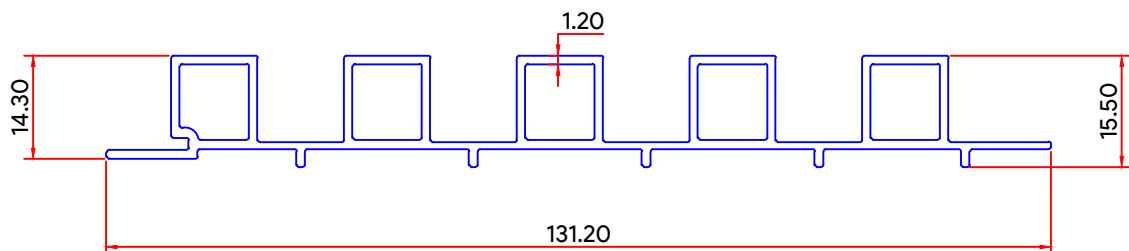

WEIGHT. : 3.660 KG / 12'



GATE & RAILING SECTION

ARCHITECTURAL

SEC. NO. : 8462

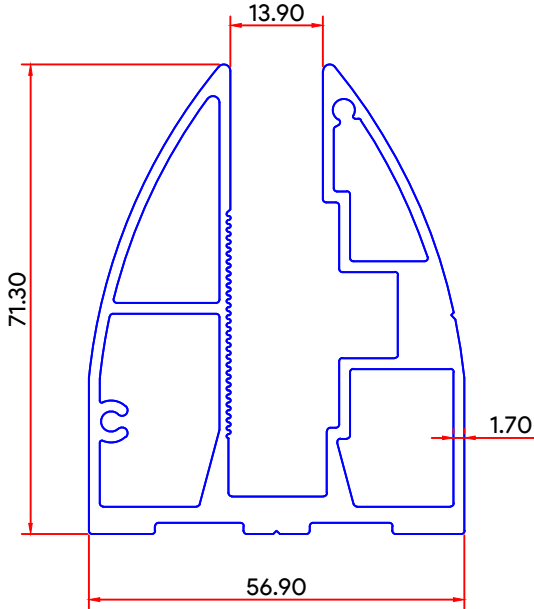

WEIGHT. : 8.300-8.650 KG / 12'

SEC. NO. : 7419

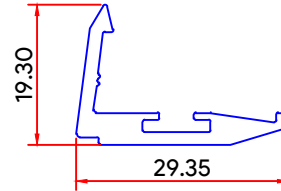

WEIGHT. : 1.165 KG / 12'

SEC. NO. : 7420

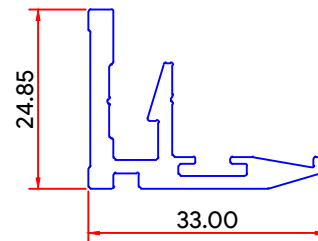

WEIGHT. : 1.855 KG / 12'

SEC. NO. : 6157

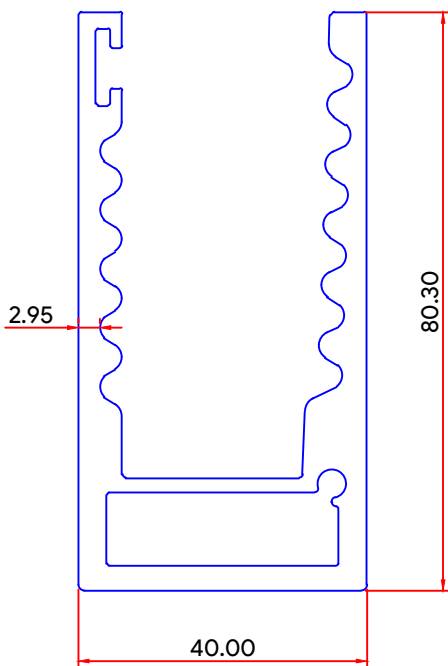

WEIGHT. : 9.040 KG / 12'

SEC. NO. : 6173

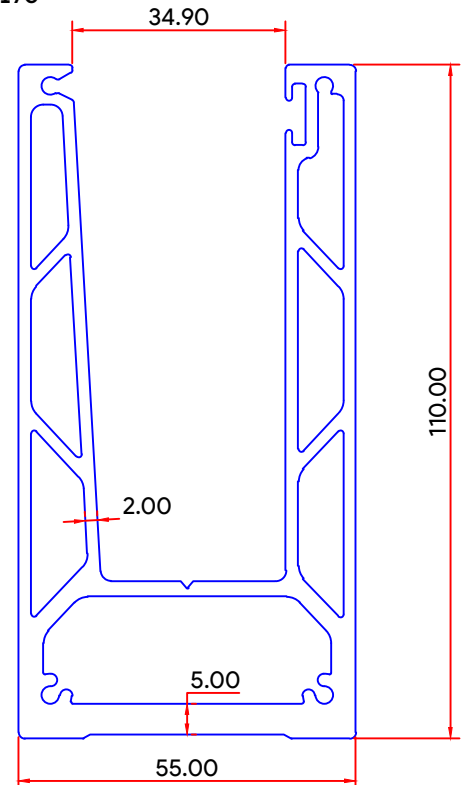

WEIGHT. : 13.915 KG / 12'



GATE & RAILING SECTION

ARCHITECTURAL

SEC. NO. : 6183

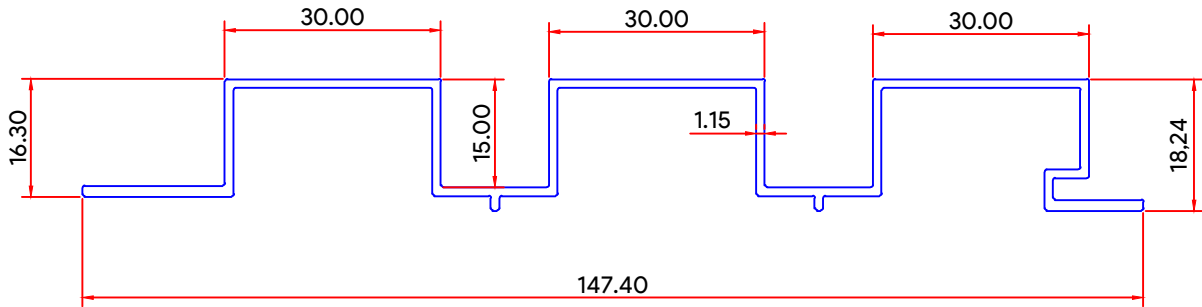

WEIGHT. : 3.100 KG / 12'

SEC. NO. : 6184

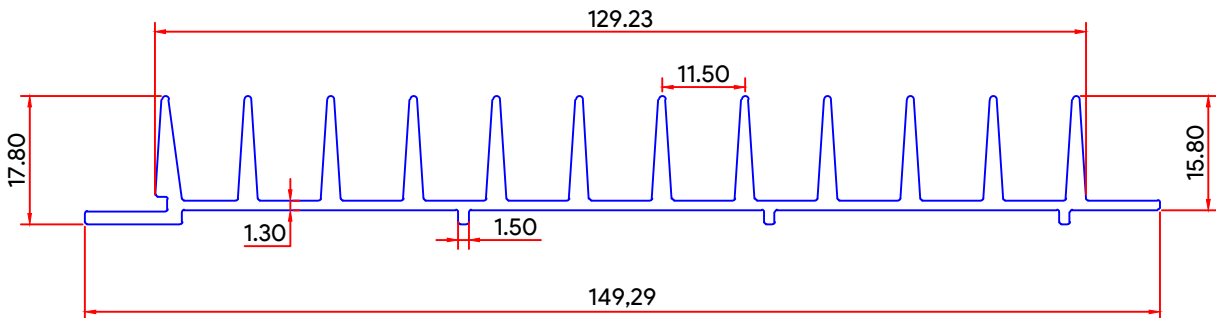

WEIGHT. : 5.370KG / 12'

SEC. NO. : 6185

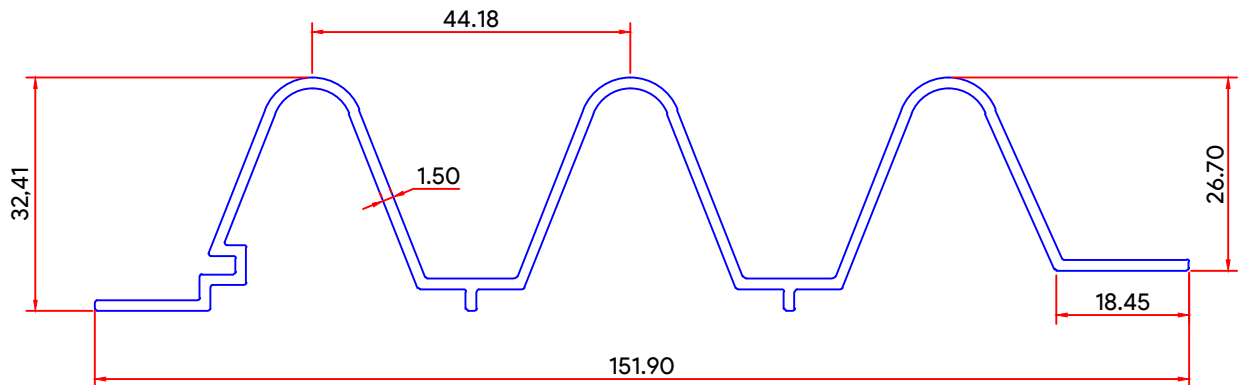

WEIGHT. : 4.065 KG / 12'



GATE & RAILING SECTION

ARCHITECTURAL

SEC. NO. : 6196

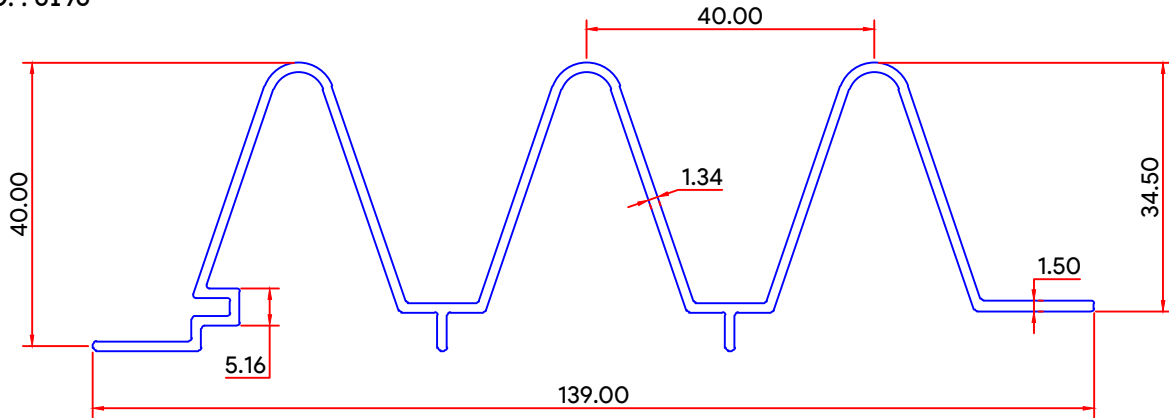

WEIGHT. : 4.010 KG / 12'

SEC. NO. : 7307-R

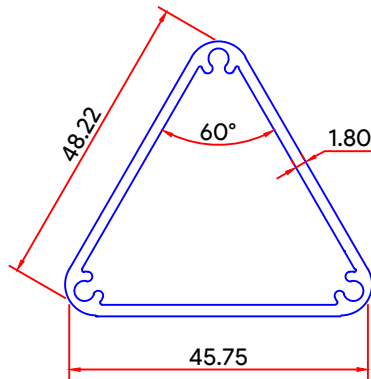

WEIGHT. : 2.737 KG / 12'

SEC. NO. : 6206

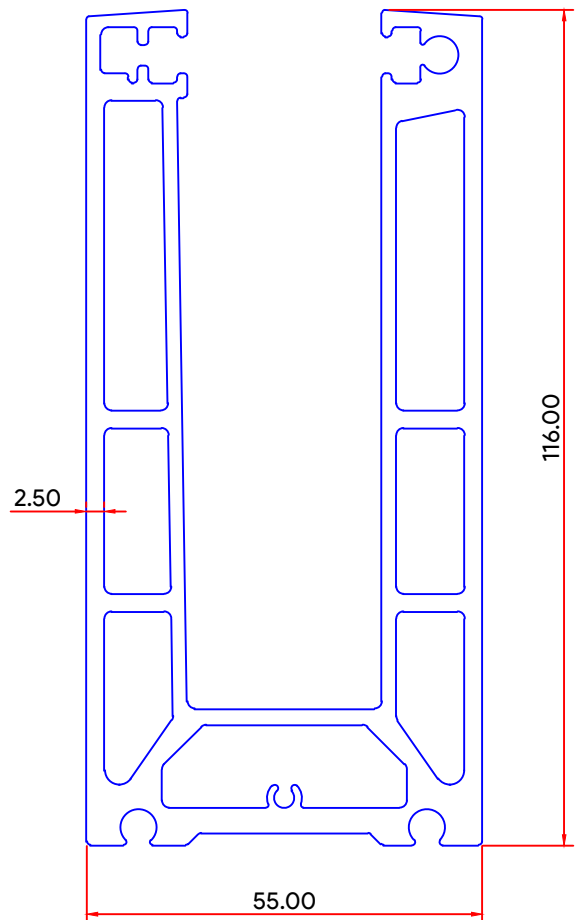

WEIGHT. : 15.290 KG / 12'

SEC. NO. : 8532

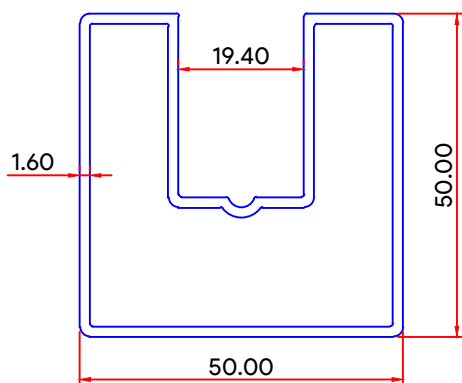

WEIGHT. : 3.952 KG / 12'



GATE & RAILING SECTION

ARCHITECTURAL

SEC. NO. : 6223

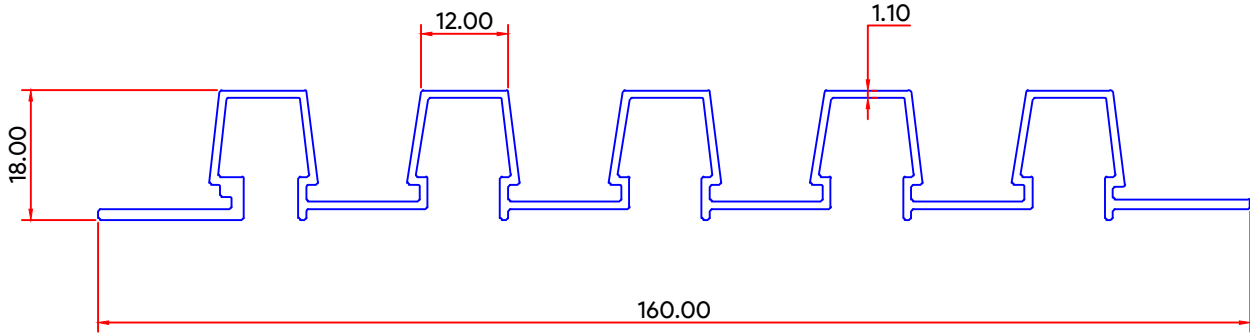

WEIGHT. : 3.858 KG / 12'

SEC. NO. : 6197

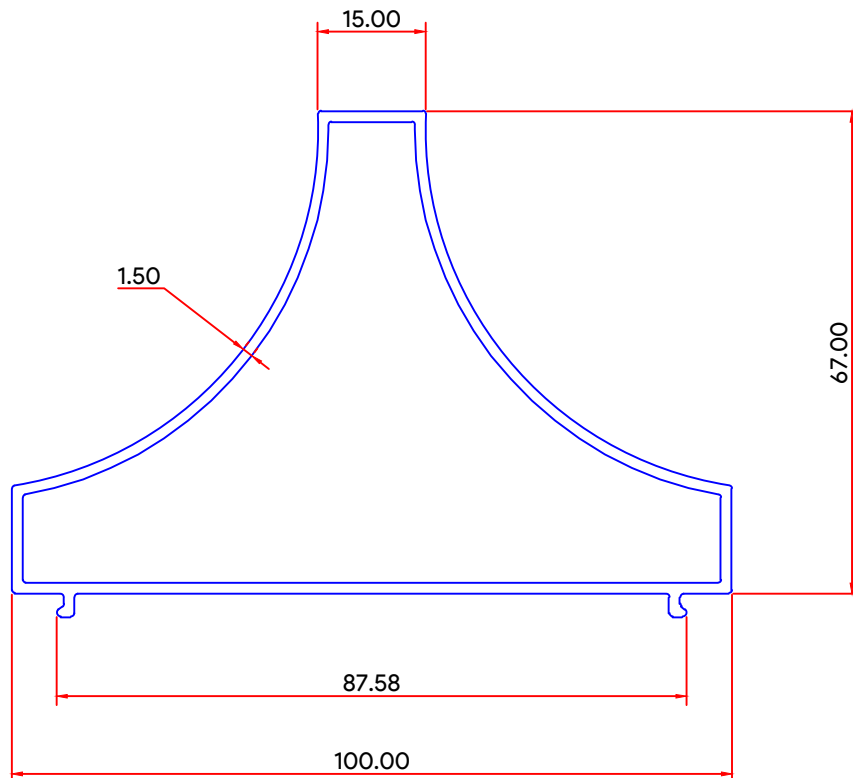

WEIGHT. : 4.357 KG / 12'



GATE & RAILING SECTION

ARCHITECTURAL

SEC. NO. : 7483

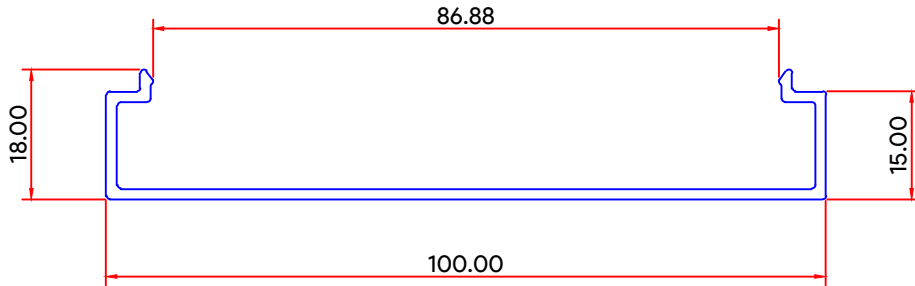

WEIGHT. : 2.105 KG / 12'

SEC. NO. : 8555

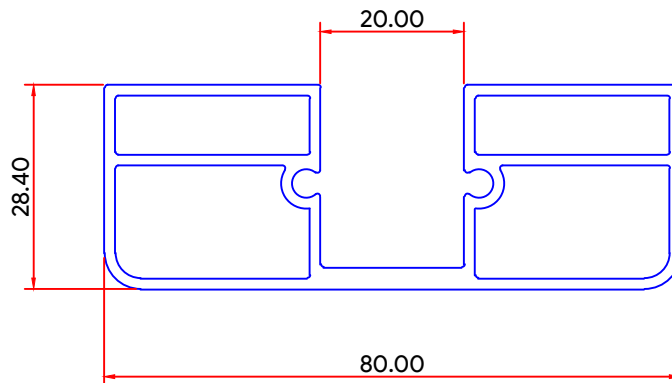

WEIGHT. : 4.775 KG / 12'

SEC. NO. : 6250

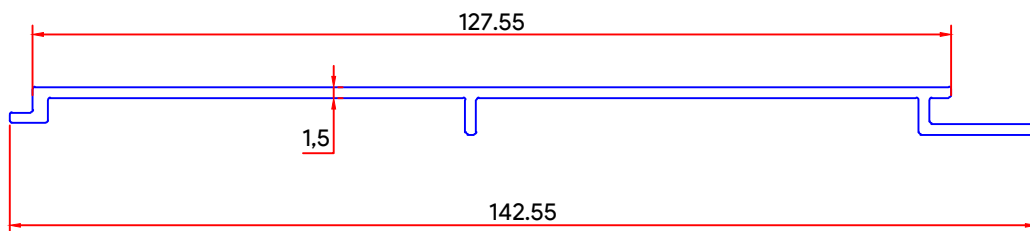

WEIGHT. : 2.380 KG / 12'



GATE & RAILING SECTION

ARCHITECTURAL

SEC. NO. : 6252

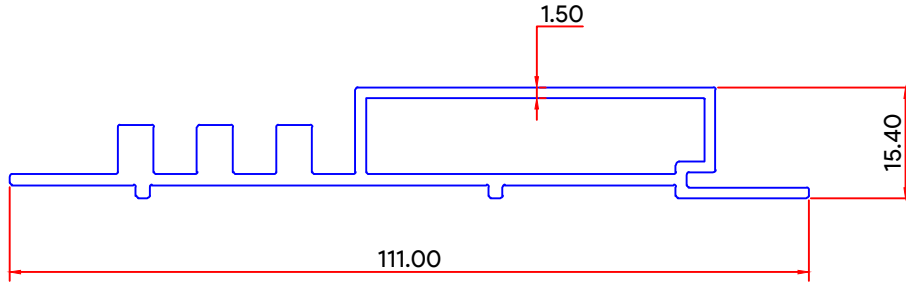

WEIGHT. : 3.870 KG / 12'

SEC. NO. : 6253

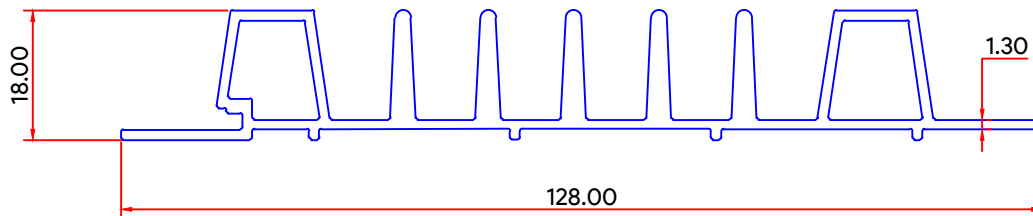

WEIGHT. : 5.000 KG / 12'

SEC. NO. : 6256

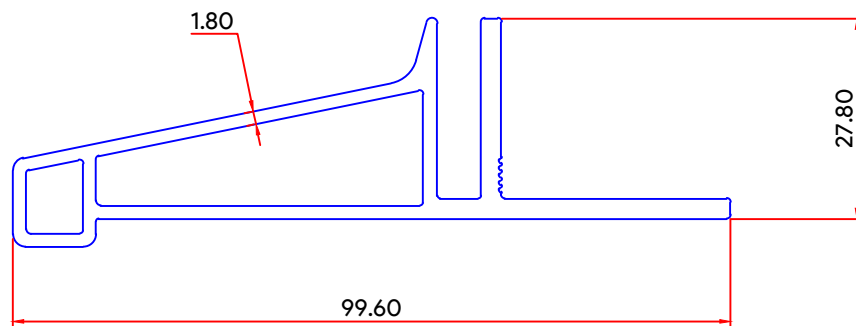

WEIGHT. : 4.780 KG / 12'



JHALANI EXTRUSION

(A UNIT OF P.R.C.M. METAL)

C-36, Riico Industrial Area, Neemrana, District : Alwar, (Raj.) 301705
Contact : 9716031516, 09953239231 E-Mail : jhalaniextrusion@yahoo.com

GATE & RAILING SECTION

ARCHITECTURAL

SEC. NO. : 6271

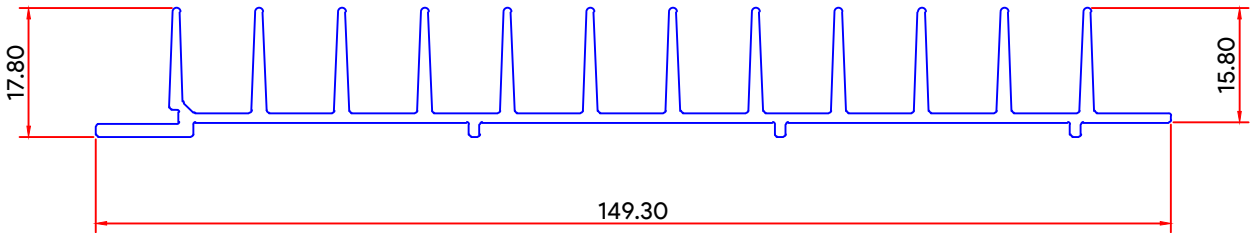

WEIGHT. : 4.700 KG / 12'

SEC. NO. : 6284

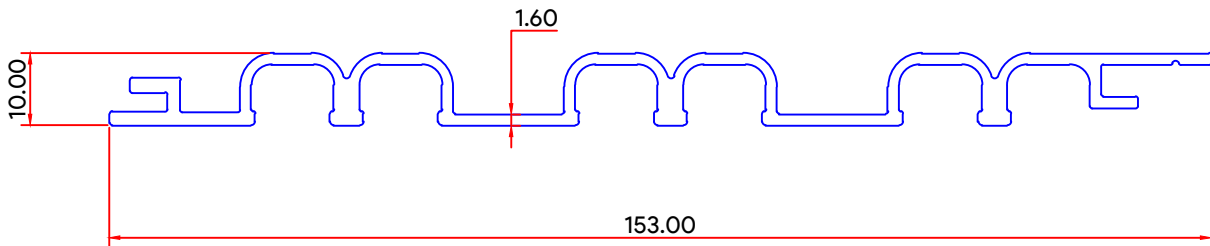

WEIGHT. : 4.050 KG / 12'

SEC. NO. : 8596

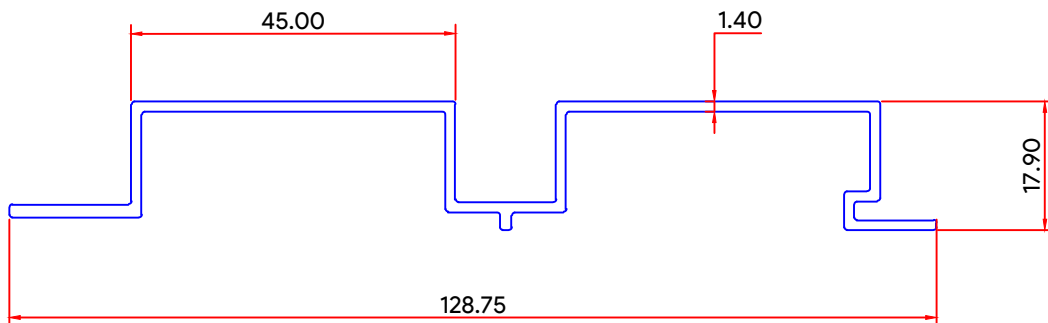

WEIGHT. : 2.812 KG / 12'

ALL DIMENSIONS ARE IN M.M.



JHALANI EXTRUSION

(A UNIT OF P.R.C.M. METAL)

C-36, Riico Industrial Area, Neemrana, District : Alwar, (Raj.) 301705

Contact : 9716031516, 09953239231 E-Mail : jhalaniextrusion@yahoo.com

GATE & RAILING SECTION

ARCHITECTURAL

SEC. NO. : 7590

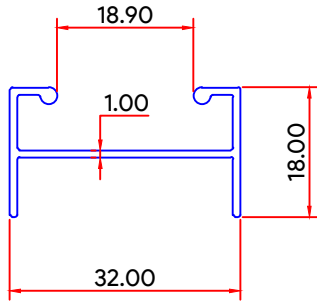

WEIGHT. : 0.810 KG / 12'

SEC. NO. : 7591

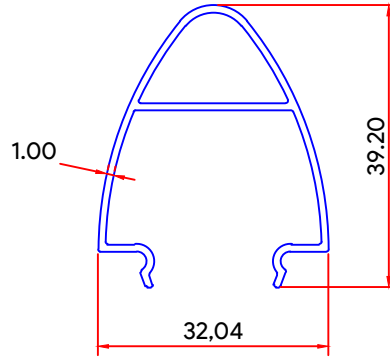

WEIGHT. : 1.211 KG / 12'

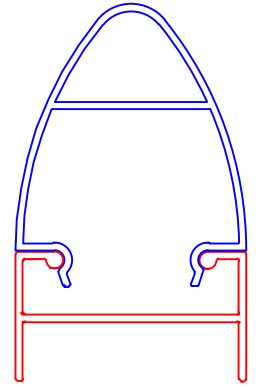

FITTING 7590 & 7591

SEC. NO. : 6291

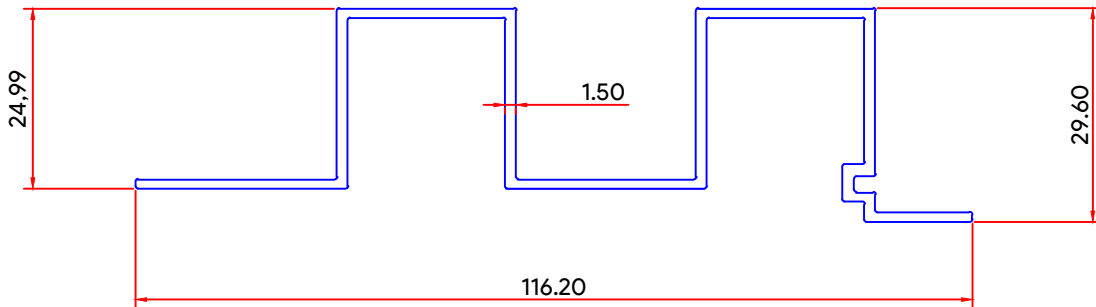

WEIGHT. : 3.055 KG / 12'

SEC. NO. : 6311

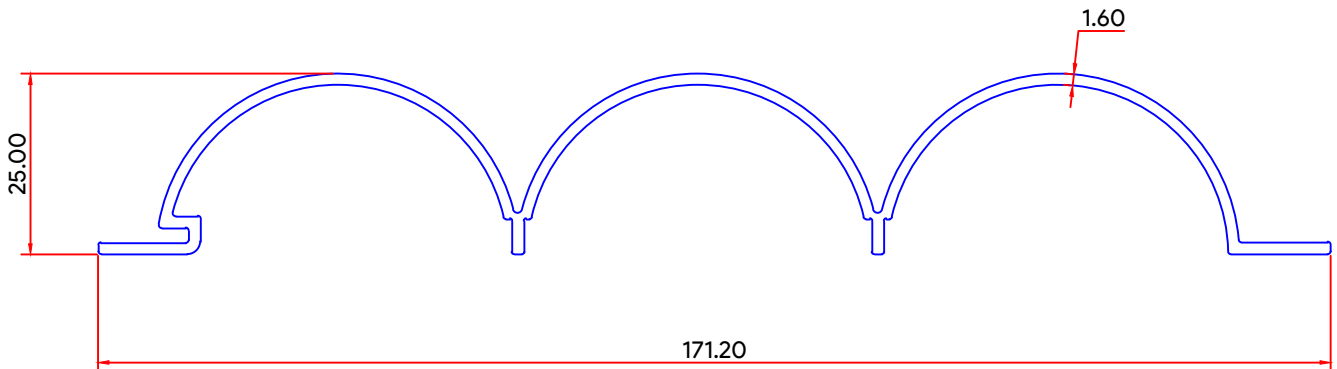

WEIGHT. : 3.935 KG / 12'

ALL DIMENSIONS ARE IN M.M.



JHALANI EXTRUSION

(A UNIT OF P.R.C.M. METAL)

C-36, Riico Industrial Area, Neemrana, District : Alwar, (Raj.) 301705

Contact : 9716031516, 09953239231 E-Mail : jhalaniextrusion@yahoo.com

GATE & RAILING SECTION

ARCHITECTURAL

SEC. NO. : 6305

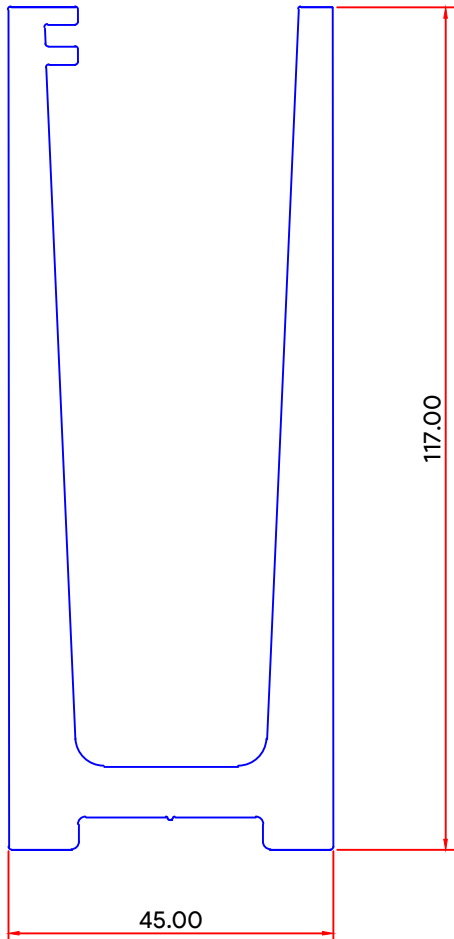

WEIGHT. : 18.990 KG / 12'

SEC. NO. : 7143

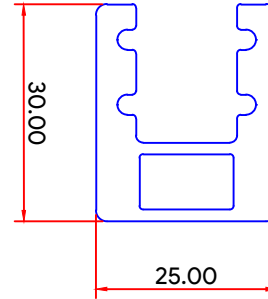

WEIGHT. : 3.500 KG / 12'

ALL DIMENSIONS ARE IN M.M.