



JHALANI EXTRUSION

(A UNIT OF P.R.C.M. METAL)

C-36, Riico Industrial Area, Neemrana, District : Alwar, (Raj.) 301705

Contact : 9716031516, 09953239231 E-Mail : jhalaniextrusion@yahoo.com

BLIND SECTION

ARCHITECTURAL

SEC. NO. : 7353

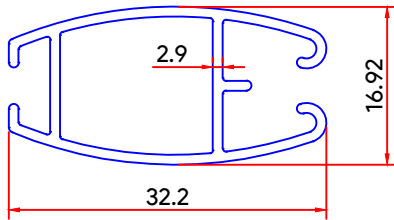

WEIGHT. : 1.00 KG / 12'

SEC. NO. : 7352

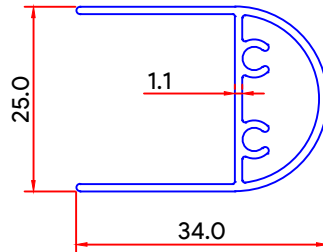

WEIGHT. : 1.20 KG / 12'

SEC. NO. : 7323

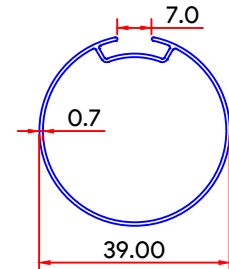

WEIGHT. : 1.150 KG / 15'

SEC. NO. : 7320

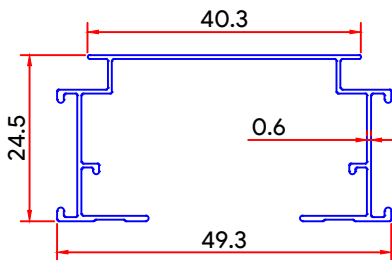

WEIGHT. : 0.880 KG / 12'

SEC. NO. : 7318

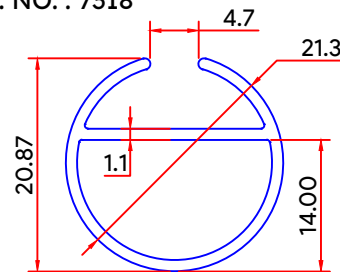

WEIGHT. : 0.830 KG / 12'

SEC. NO. : 7317

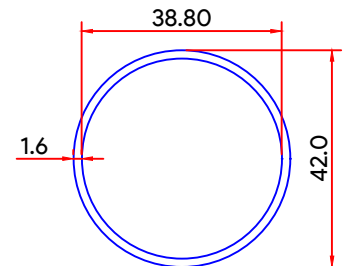

WEIGHT. : 2.0 KG / 12'

SEC. NO. : 7308

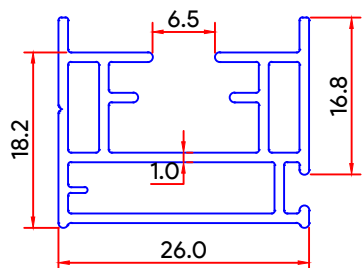

WEIGHT. : 1.35 KG / 12'

SEC. NO. : 7299

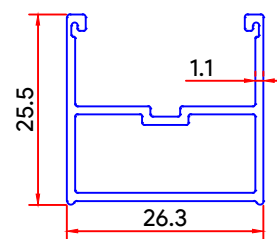

WEIGHT. : 1.140 KG / 12'

SEC. NO. : 7274

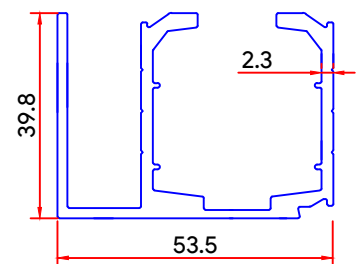

WEIGHT. : 4.320 KG / 12'

SEC. NO. : 7256

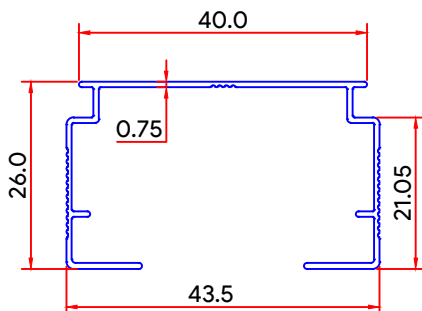

WEIGHT. : 0.880 KG / 12'

SEC. NO. : 7244

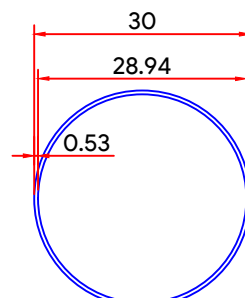

WEIGHT. : 0.600 KG / 15'

SEC. NO. : 7232

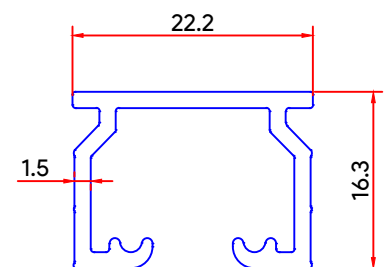

WEIGHT. : 1.250 KG / 15'

ALL DIMENSIONS ARE IN M.M.

PAGE - 01



JHALANI EXTRUSION

(A UNIT OF P.R.C.M. METAL)

C-36, Riico Industrial Area, Neemrana, District : Alwar, (Raj.) 301705

Contact : 9716031516, 09953239231 E-Mail : jhalaniextrusion@yahoo.com

BLIND SECTION

ARCHITECTURAL

SEC. NO. : 7319

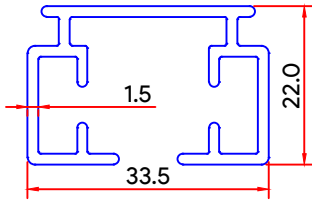

WEIGHT. : 1.793 KG / 12'

SEC. NO. : 7228

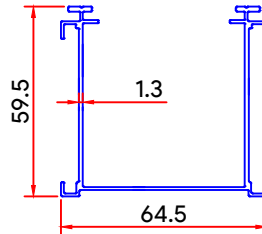

WEIGHT. : 2.600 KG / 12'

SEC. NO. : 7227

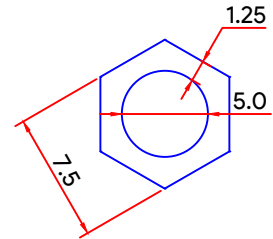

WEIGHT. : 0.286 KG / 12'

SEC. NO. : 7226

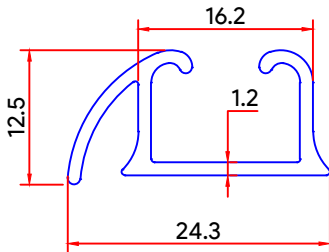

WEIGHT. : 0.717 KG / 12'

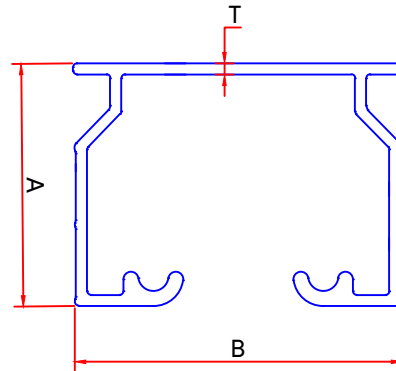

| SEC. NO. | A | B | T | WEIGHT |
|----------|-------|-------|------|-----------|
| 7218 | 16.30 | 22.00 | 1.00 | 0.700/12' |
| 7220 | 16.30 | 22.00 | 0.63 | 0.620/15' |
| 7221 | 16.30 | 22.00 | 0.75 | 0.700/15' |

SEC. NO. : 7215

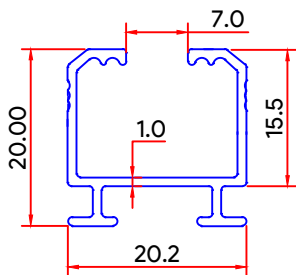

WEIGHT. : 0.775 KG / 12'

SEC. NO. : 7214

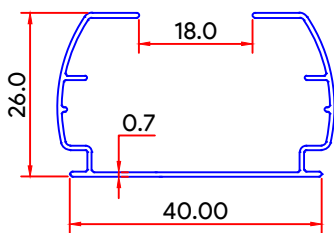

WEIGHT. : 1.10 KG / 15'

SEC. NO. : 7213

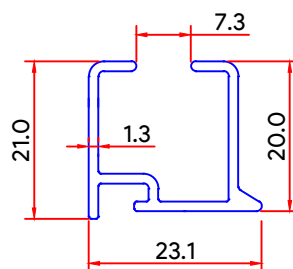

WEIGHT. : 0.980 KG / 12'

SEC. NO. : 7106

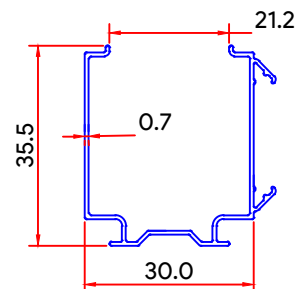

WEIGHT. : 1.050 KG / 15'



JHALANI EXTRUSION

(A UNIT OF P.R.C.M. METAL)

C-36, Riico Industrial Area, Neemrana, District : Alwar, (Raj.) 301705

Contact : 9716031516, 09953239231 E-Mail : jhalaniextrusion@yahoo.com

BLIND SECTION

ARCHITECTURAL

SEC. NO. : 8368

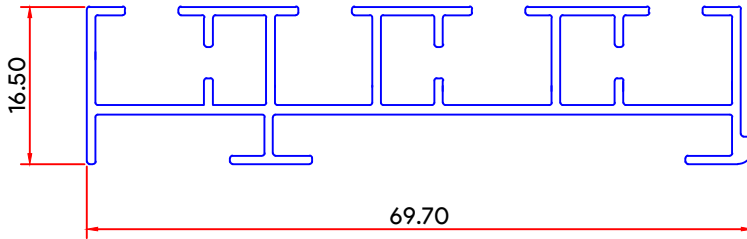

WEIGHT. : 1.950 KG / 12'

SEC. NO. : 7178

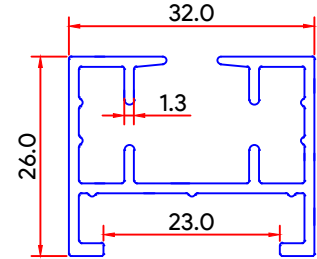

WEIGHT. : 1.710 KG / 12'

SEC. NO. : 7137

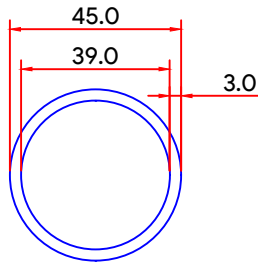

WEIGHT. : 3.900 KG / 12'

SEC. NO. : 7158

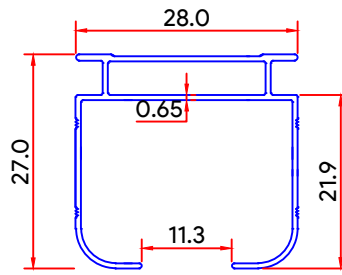

WEIGHT. : 0.950 KG / 15'

SEC. NO. : 7177

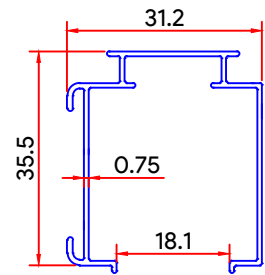

WEIGHT. : 0.940 KG / 12'

SEC. NO. : 7121

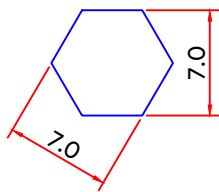

WEIGHT. : 0.410 KG / 12'

SEC. NO. : 7084

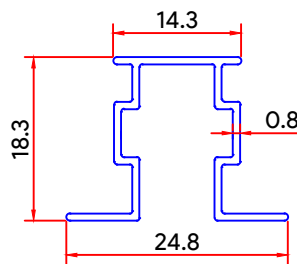

WEIGHT. : 0.550 KG / 12'

SEC. NO. : 7068

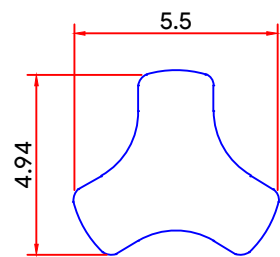

WEIGHT. : 0.150 KG / 12'

SEC. NO. : 7057

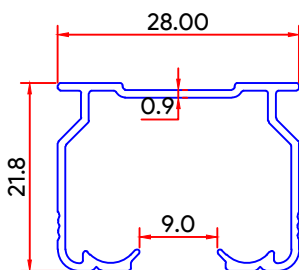

WEIGHT. : 0.800 KG / 12'

SEC. NO. : 7031

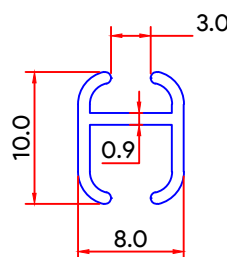

WEIGHT. : 0.256 KG / 12'

SEC. NO. : 7030

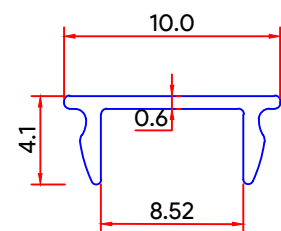

WEIGHT. : 0.111 KG / 12'

ALL DIMENSIONS ARE IN M.M.

PAGE - 03



BLIND SECTION

ARCHITECTURAL

SEC. NO. : 7025

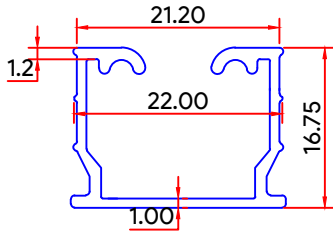

WEIGHT. : 1.00 KG / 15'

SEC. NO. : 7022

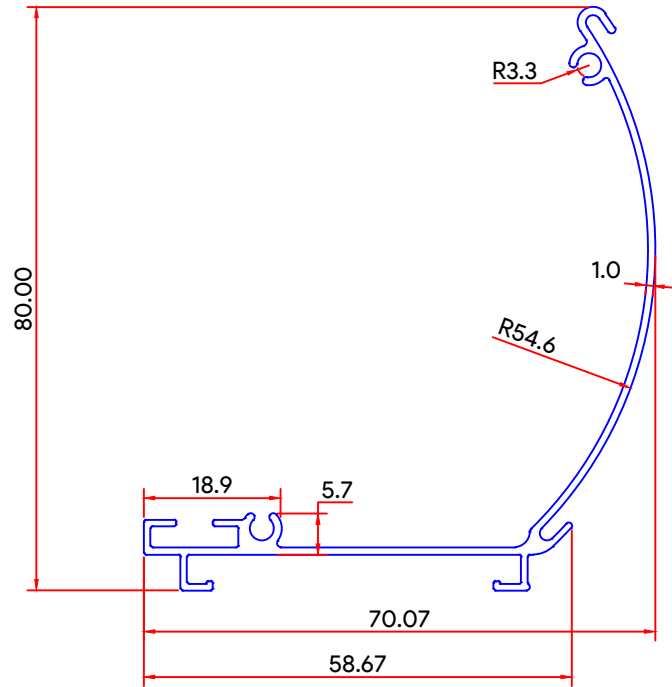

WEIGHT. : 1.960 KG / 12'

SEC. NO. : 7008

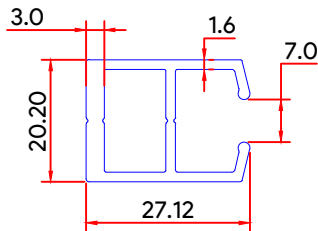

WEIGHT. : 1.750 KG / 12'

SEC. NO. : 7005

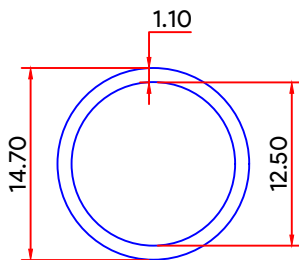

WEIGHT. : 0.465 KG / 12'

SEC. NO. : 7004

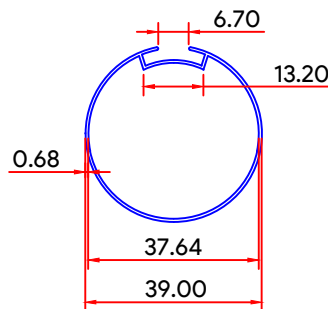

WEIGHT. : 0.890 KG / 12'

SEC. NO. : 7003

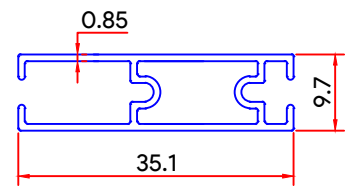

WEIGHT. : 1.100 KG / 15'

SEC. NO. : 7002

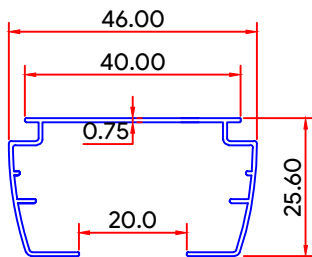

WEIGHT. : 0.945 KG / 12'

SEC. NO. : 7001

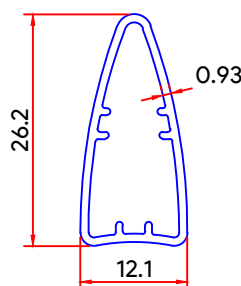

WEIGHT. : 0.615 KG / 12'

SEC. NO. : 7217

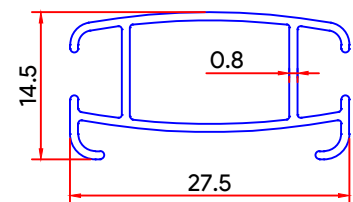

WEIGHT. : 0.716 KG / 12'



BLIND SECTION

ARCHITECTURAL

SEC. NO. : 7212

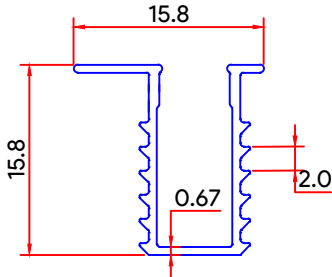

WEIGHT. : 0.375 KG / 12'

SEC. NO. : 7216

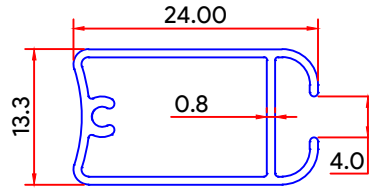

WEIGHT. : 0.650 KG / 12'

SEC. NO. : 7219

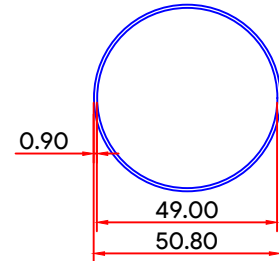

WEIGHT. : 1.390 KG / 12'

SEC. NO. : 7465

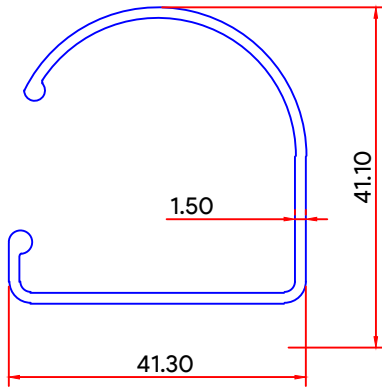

WEIGHT. : 1.860 KG / 12'

SEC. NO. : 7433

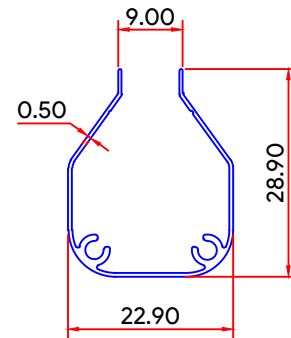

WEIGHT. : 0.545 KG / 12'

SEC. NO. : 7517

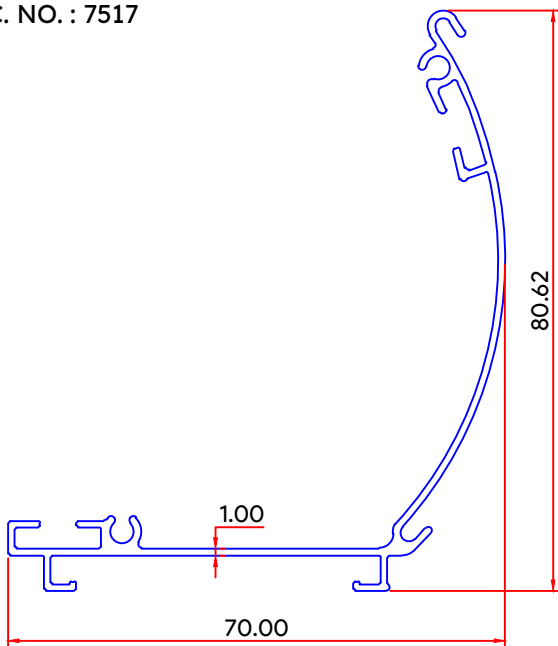

WEIGHT. : 2.059 KG / 12'

SEC. NO. : 7597

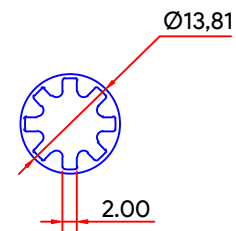

WEIGHT. : 0.768 KG / 12'

SEC. NO. : 7632

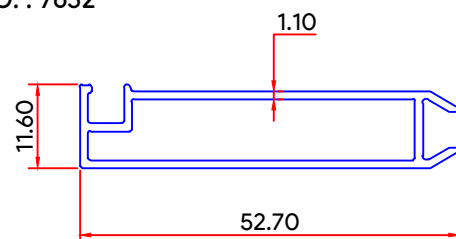

WEIGHT. : 1.400 KG / 12'



BLIND SECTION

ARCHITECTURAL

SEC. NO. : 7633

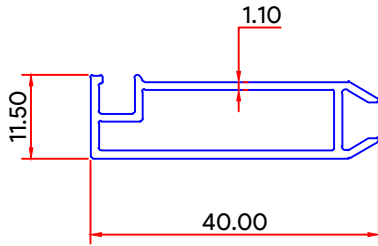

WEIGHT. : 1.128 KG / 12'

SEC. NO. : 7592

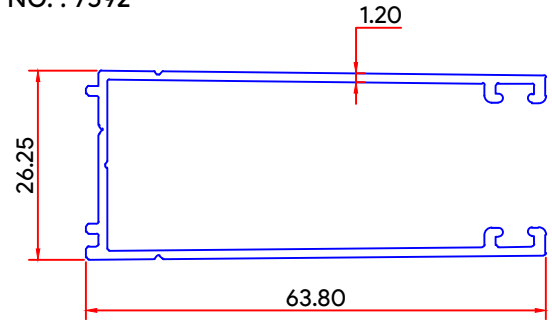

WEIGHT. : 2.020 KG / 12'

SEC. NO. : 7623

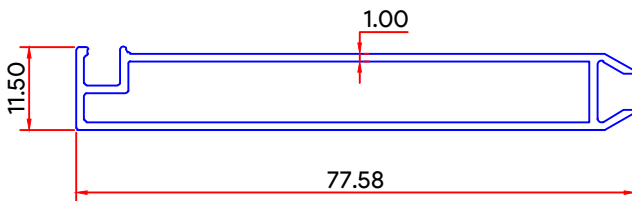

WEIGHT. : 1.942 KG / 12'